

# SHORT CONVEYORS



# Regular Hopper Conveyors



## DRIVE OPTIONS

MODEL	HYDRAULIC	HP ELECTRIC
TCX 1222	✓	✓
TCX 1227	✓	✓
TCX 1232	✓	✓
1535 TD	✓	✓
1540 TD	✓	✓
1545 TD	✓	✓

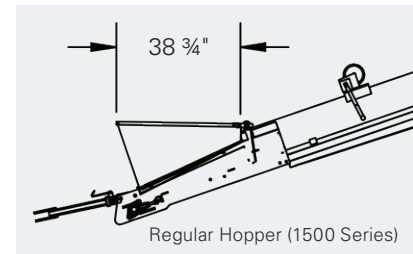

MODEL	BELT LENGTH	WEIGHT LBS.	UP OPERATION		DOWN OPERATION		WIDTH
			A	B	A	B	
TCX 1222	46' 6"	1000	10' 8"	7' 9"	7' 11"	8' 4"	8'
TCX 1227	56' 2"	1030	13' 3"	9' 2"	8' 11"	9' 11"	8'
TCX 1232	66'	1150	16' 4"	14' 6"	8'	14' 10"	8'
1535 TD	70' 2"	1582	16.8"	12"	10.7"	12.8"	7.5'
1540 TD	80' 2"	1681	18.8"	15.2"	11.2"	15.5"	7.5'
1545 TD	90' 2"	1780	21.5"	19.1"	11.9"	19.5"	7.5'

## TCX 12 Series

- Capacity rated up to 3,800 BPH
- 2-Ply Chevron Belt with Poly Slider Backing
- 205-75-14 Tires
- Collapsible Intake Hopper
- Manual Lift Winch
- Standard with Weather Guards
- Poly Return Rollers
- Powder Coat Paint
- Available in 22', 27' and 32' lengths

## 1500 Series

- Capacity rated up to 6,000 BPH
- 2-Ply Chevron Belt with Nylon Slider Backing
- Available in lengths from 35' - 45'
- 10" diameter, 14 GA tube
- Standard with Weather Guards
- Powder Coat Paint
- 40' and 45' come standard with pinch top drive

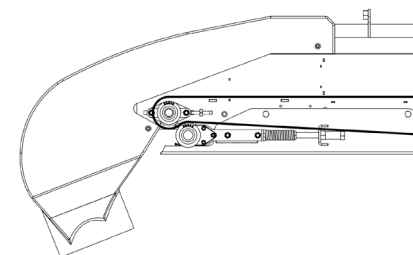
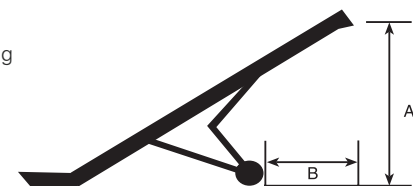

## Pinch Top Drive

Unique to AGI Batco, the true pinch top drive allows for maximum drive roller traction in all types of conditions. Electric or hydraulic drive options available.

# Field Loader Conveyors

## CUB Hopper

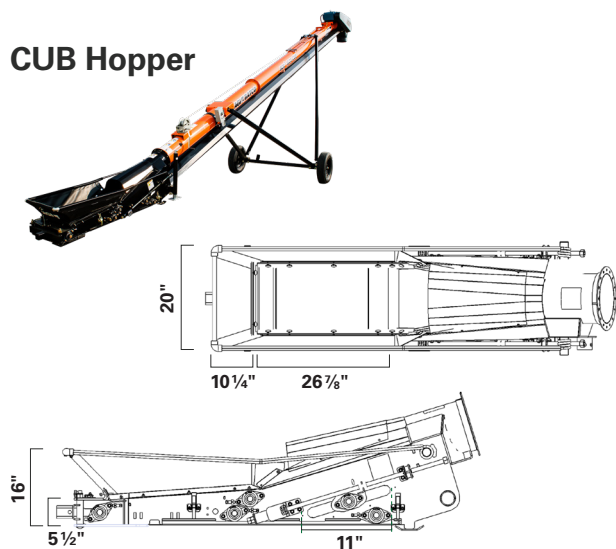

## Regular Hopper

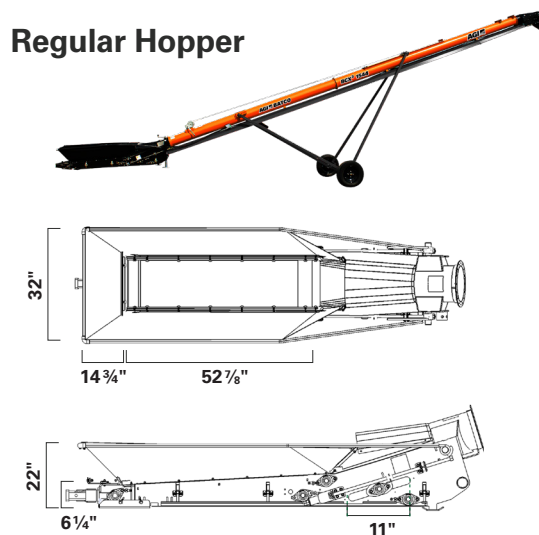

### DRIVE OPTIONS

MODEL	PINCH TOP DRIVE	PINCH S-DRIVE	HYDRAULIC	ELECTRIC	GAS
1539 FL	✓	—	✓	✓	—
1544 FL	✓	—	✓	✓	—
1549 FL	✓	✓	✓	✓	✓
2045 FMD	—	✓	—	✓	✓

### FIELD LOADER SPECIFICATIONS

MODEL	BELT LENGTH	WEIGHT LBS	UP-OPERATION		DOWN-OPERATION		WIDTH	HP ELEC	HP GAS	HP HYD. (CU.IN.)
			A	B	A	B				
1535 TD	70' 2"	1582	16.8	12	10.7	12.8	7.5	7.5	N/A	6.2 (2000 SERIES)
1540 TD	80' 2"	1681	18.8	15.2	11.2	15.5	7.5	7.5	N/A	6.2 (2000 SERIES)
1545 TD	90' 2"	1780	21.5	19.1	11.9	19.5	7.5	10	N/A	6.2 (2000 SERIES)
1539 CUB	81' 3"	1500	19.2	15.8	8.9	16.7	7.5	10	N/A	6.2
1544 CUB	91' 3"	1800	19.9	18.7	10.5	18.9	7.5	10/12.5	N/A	6.2
1549 CUB	101' 3"	2000	19.3	21.7	10.6	20.9	7.5	12.5	N/A	6.2
1539 FLTD	86' 3"	1600	20.2	19.2	8.7	18.6	7.5	10	N/A	6.2
1544 FLTD	96' 3"	1900	20.8	20.2	10.1	21	7.5	10/12.5	N/A	6.2
1549 FLTD	106' 3"	2100	20.8	23.2	10.9	23.2	7.5	12.5	N/A	6.2
BCX <sup>3</sup> 1549	110' 8"	3800	20.9	21.4	9.7	22.9	7.5	N/A	32-33	N/A
FX 2045 FL S-Drive	114'	3775	20'	13'	8.4'	N/A	8.4	20	35-40	N/A

## BCX<sup>3</sup>

- Capacity ranges from 6,000 to 10,000 BPH
- Redesigned S-Drive with longer take-up which can be adjusted with normal tools and no longer runs the risk of over-tightening
- Grain flows straight down from the spout with the newly redesigned No-Nonsense Hood
- Precision-made urethane hopper seals secures the belt to the hopper bed reducing the chance of spillage/leakage
- Under hopper skid plate stops debris from touching the bottom of the belt, keeping it off the belt and protecting the belt from damage
- Three optional gas engines to choose from: 33 HP EFI, 32 HP Carb, or 37 HP EFI
- Available with the motor above or below the tube

A up is conveyor discharge height (from bottom of discharge hood) at 30 degrees

A down is overall conveyor height (from top of discharge hood)

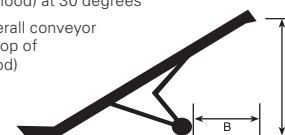

## 2045 FL FMD

- Capacity rated up to 14,000 BPH
- 14" diameter, 12 GA tube

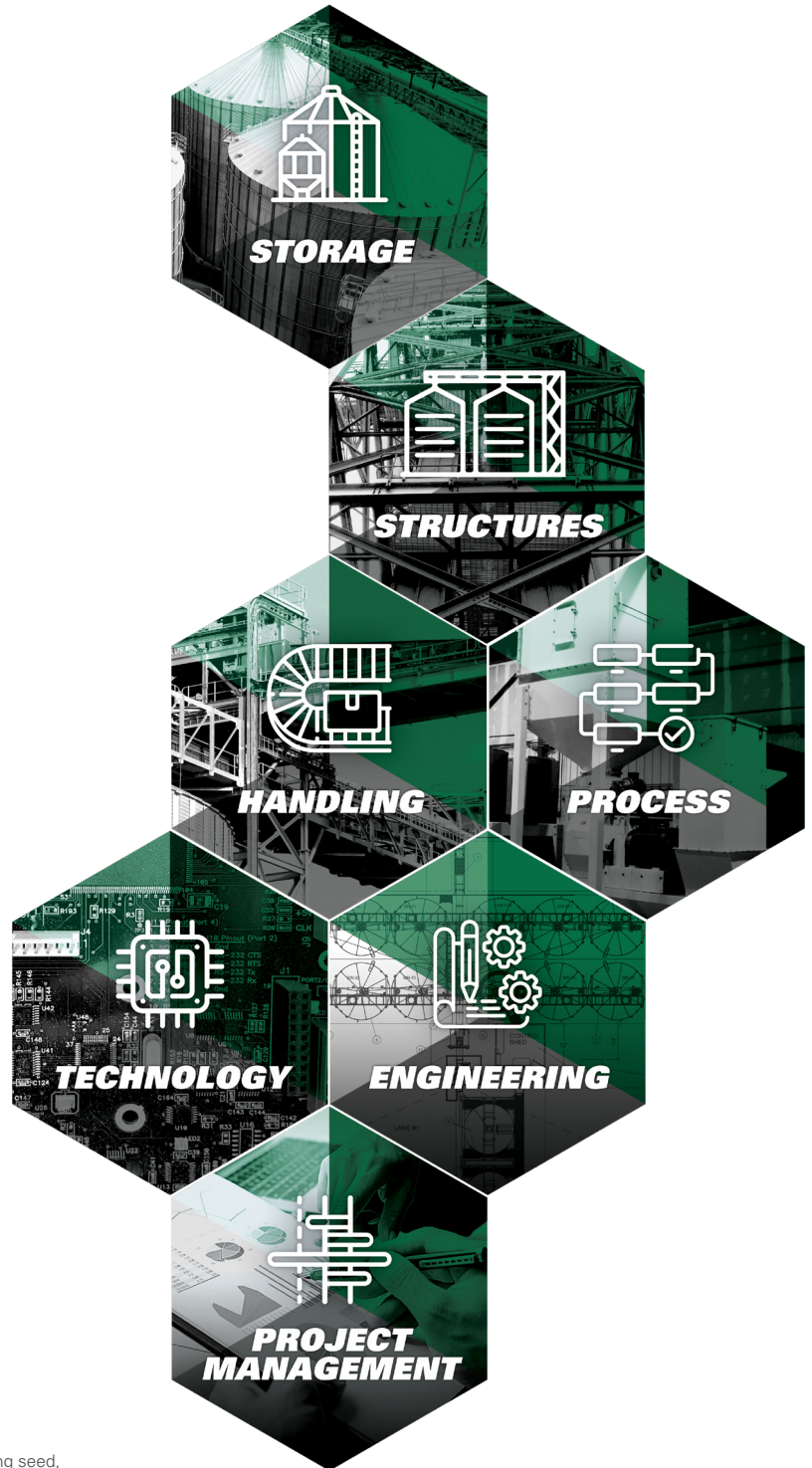

**BATCO is an AGI Brand.**

AGI is a leading provider of equipment solutions for agriculture bulk commodities including seed, fertilizer, grain, and feed systems with a growing platform in providing equipment and solutions for food processing facilities. AGI has manufacturing facilities in Canada, the United States, the United Kingdom, Brazil, India and Italy and distributes its products globally.

**AGI  BATCO**

198 Commerce Drive, Winnipeg, Manitoba, Canada R3P 0Z6  
1.855.432.1990 | [aggrowth.com/batco](http://aggrowth.com/batco)

AGGROWTH.COM [aggrowthintl](#) [📺](#) [🐦](#) [in](#) [f](#) [o](#)